



User Guide

Document Number

AS7421

64-Channel Near-Infrared Sensor

Evaluation Kit

v0-01 • 2022-Oct-18

Content Guide

1	Introduction	3	5	Description of the GUI Main Menu Areas.....	15
1.1	Kit Content.....	3	5.1	Settings Area	15
1.2	Ordering Information	4	5.2	Header Line Area	29
2	Getting Started	5	5.3	Plotting/Diagram Area	31
2.1	Software Installation	5	6	Custom Calibration.....	33
2.2	Connection procedure	6	6.1	EEPROM	35
3	Hardware Description	7	7	Additional Documents.....	37
3.1	Hardware Architecture – Unicom Microcontroller Board	7	8	Revision Information	38
3.2	Sensor Board Overview	7	9	Legal Information.....	39
3.3	Sensor Board Connector Pinout Description	8			
3.4	Schematic & Assembly Diagrams of the Sensor Board	9			
4	Software Description	12			
4.1	Graphical User Interface (GUI).....	12			

1 Introduction

The AS7421 is a 64-channel near-infrared sensor for spectral identification and spectral footprint analysis. The spectral response of the sensor is defined in the wavelengths from approximately 750 nm to 1050 nm, and the channels are equally distributed over the mentioned range. In a spectral measurement, all 64 channels are processed automatically by 16 parallel sampling ADCs with four consecutive integration cycles.

The AS7421 Evaluation Kit comes with Windows-based client software (Graphical User Interface - GUI) to evaluate the features of the AS7421 sensor. This user guide describes the features and functions of the evaluation kit.

1.1 Kit Content

The AS7421 Evaluation Kit contains the following:

Figure 1:
AS7421 Evaluation Kit content



Item No.	Item	Comment
1	AS7421 Sensor Board	Evaluation Sensor Board with the AS7421 64-Channel NIR Spectral sensor.
2	Unicom Microcontroller Board	Controller board to organize Data Transfer between the sensor Board and the PC.
3	USB Stick	Documents, software, and calibration files.
4	Ribbon cable 10 pole	To connect the sensor board with the Unicom Controller Board.
5	Micro USB connector cable	To connect the Unicom Controller Board with a Windows-PC.
6	Reference target	

1.2 Ordering Information

Ordering Code	Description
Evaluation Kit	AS7421 64-Channel Near-Infrared Sensor

2 Getting Started

The AS7421 64-channel near-infrared spectral sensor evaluation kit contains two PCB boards: a sensor board with the AS7421 sensor and a Unicom board based on an STM32 ARM Cortex microcontroller. To perform spectral measurements, the boards must be connected with a ribbon cable and via a micro-USB to the Windows PC. Additionally, the AS7421 Windows-based client software must be installed.

An optomechanical stack is pre-assembled onto the AS7421 sensor board.

Figure 2:
AS7421 Evaluation Kit



2.1 Software Installation

The software, calibration data, and documentation are stored on the USB stick as part of the evaluation kit.

It is important to install the EVK software, “AS7421 Windows Demo GUI”, on a Windows PC before connecting the Unicom board the first time. Start the executable “*setup.exe*” or MSI file and follow the installation instructions.

If an older release version of the client software exists on your PC, it must be uninstalled first.

During the installation process, additionally required Windows components such as a .NET framework will be installed aside from the application. After the installation, a new icon is available on your desktop – “AS7421 Windows Demo GUI”.

In some cases, the installation may fail due to a previously incomplete Windows component installation. In such a case, the installation process will stop with an error and show the module causing the error. This module/component must first be uninstalled and the setup executed again.

2.2 Connection procedure

After installing the drivers and software, the following steps are necessary to make the system ready for measurements.

1. Connect the AS7421 sensor board with the Unicom microcontroller board via the ribbon flex cable provided.
2. Afterward, connect the Unicom microcontroller board via the micro USB cable to the PC (Figure 3).
3. Both green LEDs on the Unicom microcontroller board and the green LED on the sensor board will light up, signaling the correct operation. The board will be registered as a virtual COM port in Windows.
4. Finally, start the “AS7421 Windows Demo GUI” on your computer.

Figure 3:
Connection of the PCB Boards to the PC

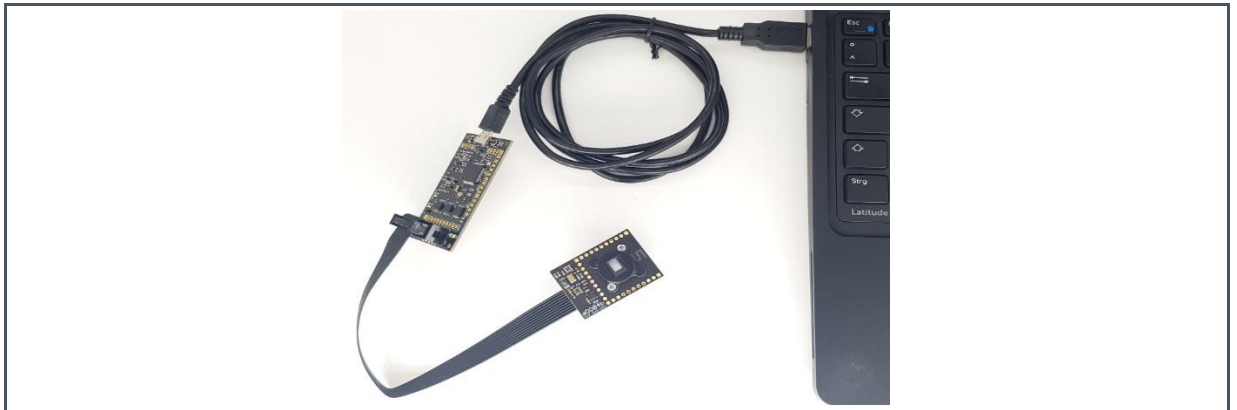

3 Hardware Description

The AS7421 sensor board is used to execute spectral measurements, whilst the Unicom microcontroller board acts as a communication bridge between the sensor board and PC.

3.1 Hardware Architecture – Unicom Microcontroller Board

Figure 4:
Hardware architecture of the Unicom microcontroller board

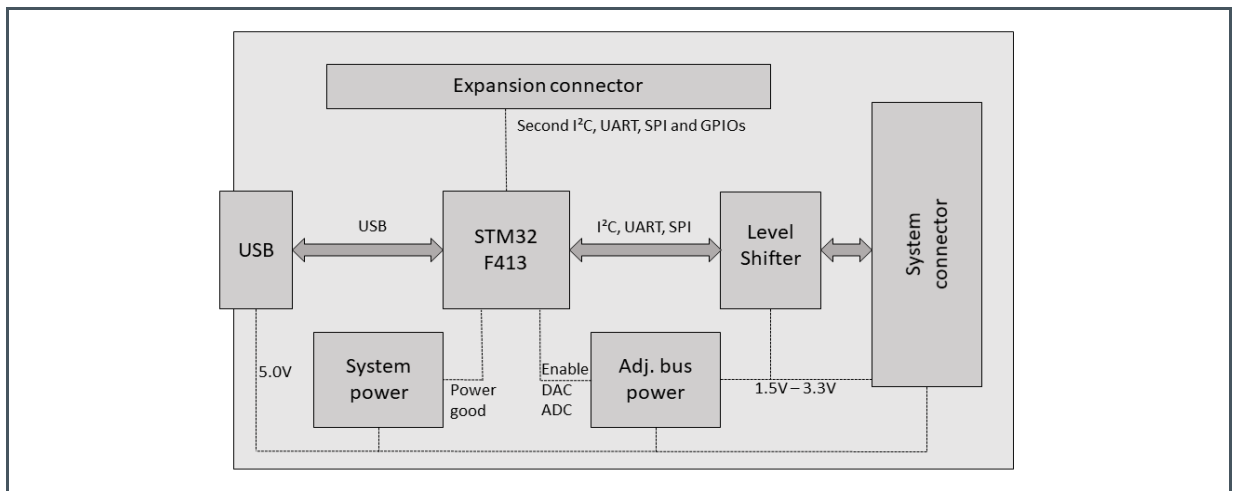

The Unicom microcontroller board provides power and data communication to the sensor board and connects the EVK with the PC. The microcontroller firmware controls the communication between the sensor board and the PC. The board also contains a logic level shifter. It provides a way to connect boards with different supporting voltage levels. There are two operational green LEDs, H1 and H2, on the board. The Unicom board can be used with different ams-OSRAM spectral sensors, appropriate firmware, and client software. For more details, please refer to the Unicom board datasheet.

3.2 Sensor Board Overview

The sensor board is designed around the AS7421 64-Channel NIR Spectral sensor. An optical stack is mounted on the board and a light diffuser is glued directly to the sensor. For easy handling, an adapter is available on the backside of the board. The sensor board with the adapter is mountable on an optical bench with 16mm or 25mm mounting systems.

Figure 5:
Top view of the AS7421 sensor board

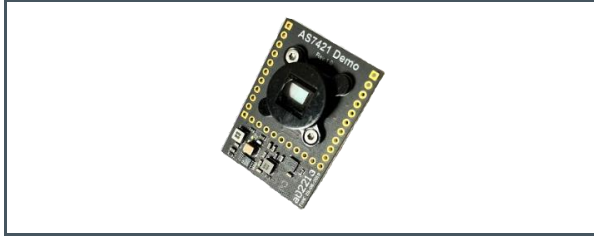
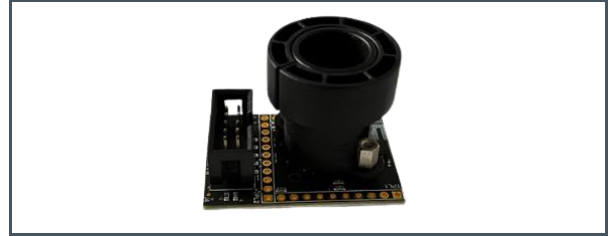

Figure 6:
Bottom view of the AS7421 sensor board with the mounting holder



3.3 Sensor Board Connector Pinout Description

Figure 7:
AS7421 sensor board J4 Jumper Pin

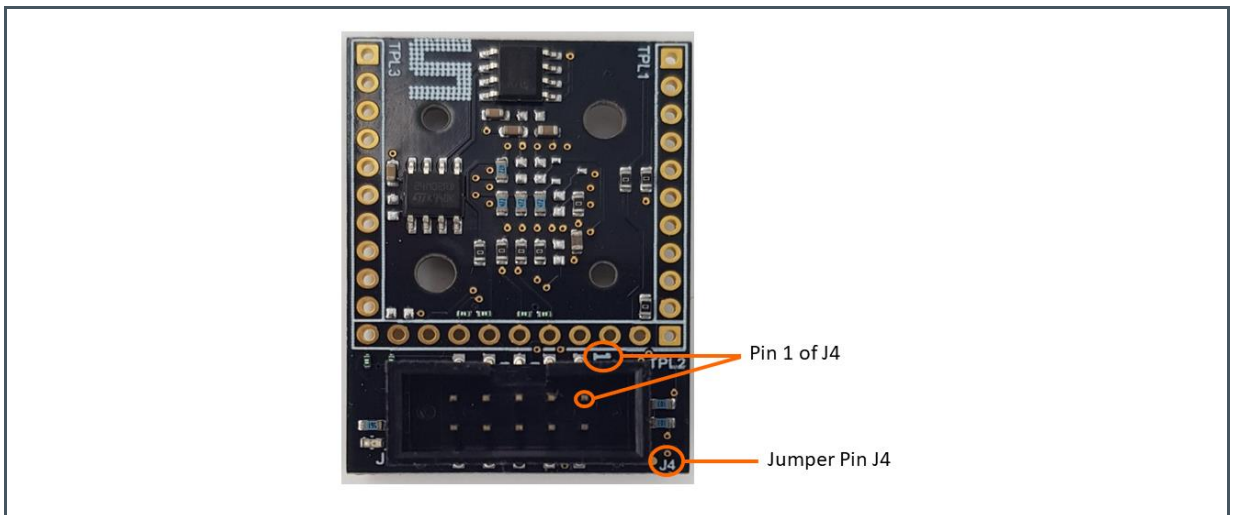

Figure 8:
J4 Pinout Description

Pin Number	Net Name	Function
1	VCC1	5V Power Supply
2	VCC2	Power Supply from 1.5V to 3.3V
3	GND	Ground
4	SDA	I ² C Data Signal
5	SCL	I ² C Clock Signal
6	INT	Interrupt Signal

Pin Number	Net Name	Function
7	Reset	Reset Signal
8	GND	Ground
9	GPIO3	Not connected
10	GPIO4	Not connected

3.4 Schematic & Assembly Diagrams of the Sensor Board

The schematic and assembly diagrams of the AS7421 sensor board are shown in Figure 9 to Figure 11.

Figure 9:
AS7421 Sensor Board schematic 1

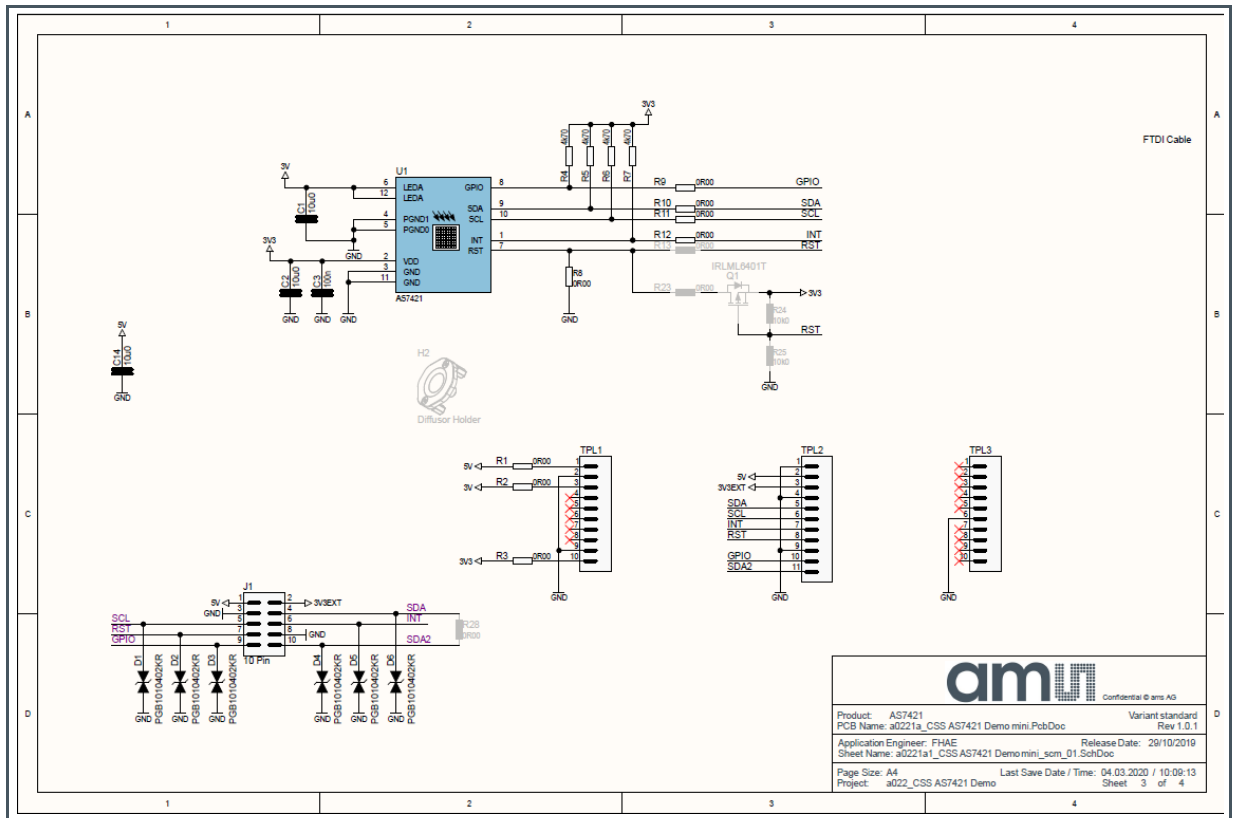

Figure 10:
AS7421 Sensor Board schematic 2

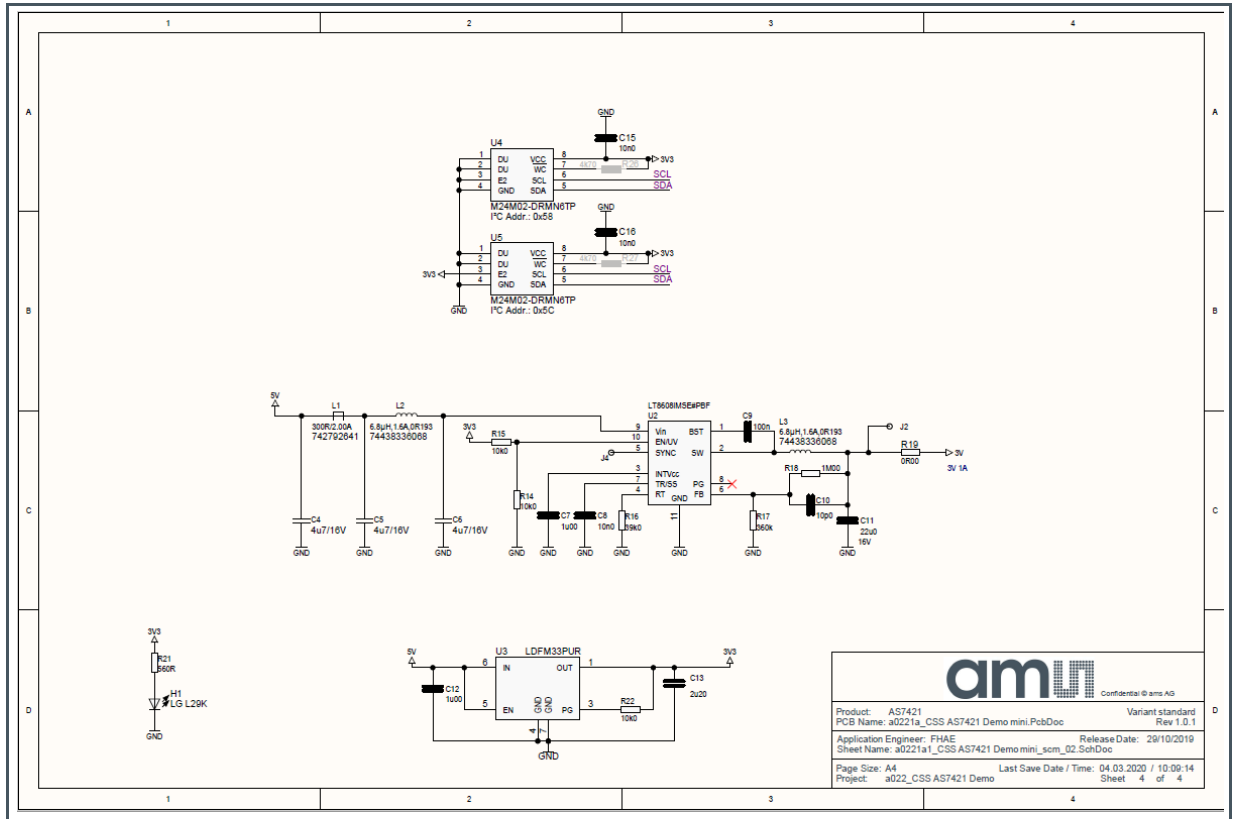
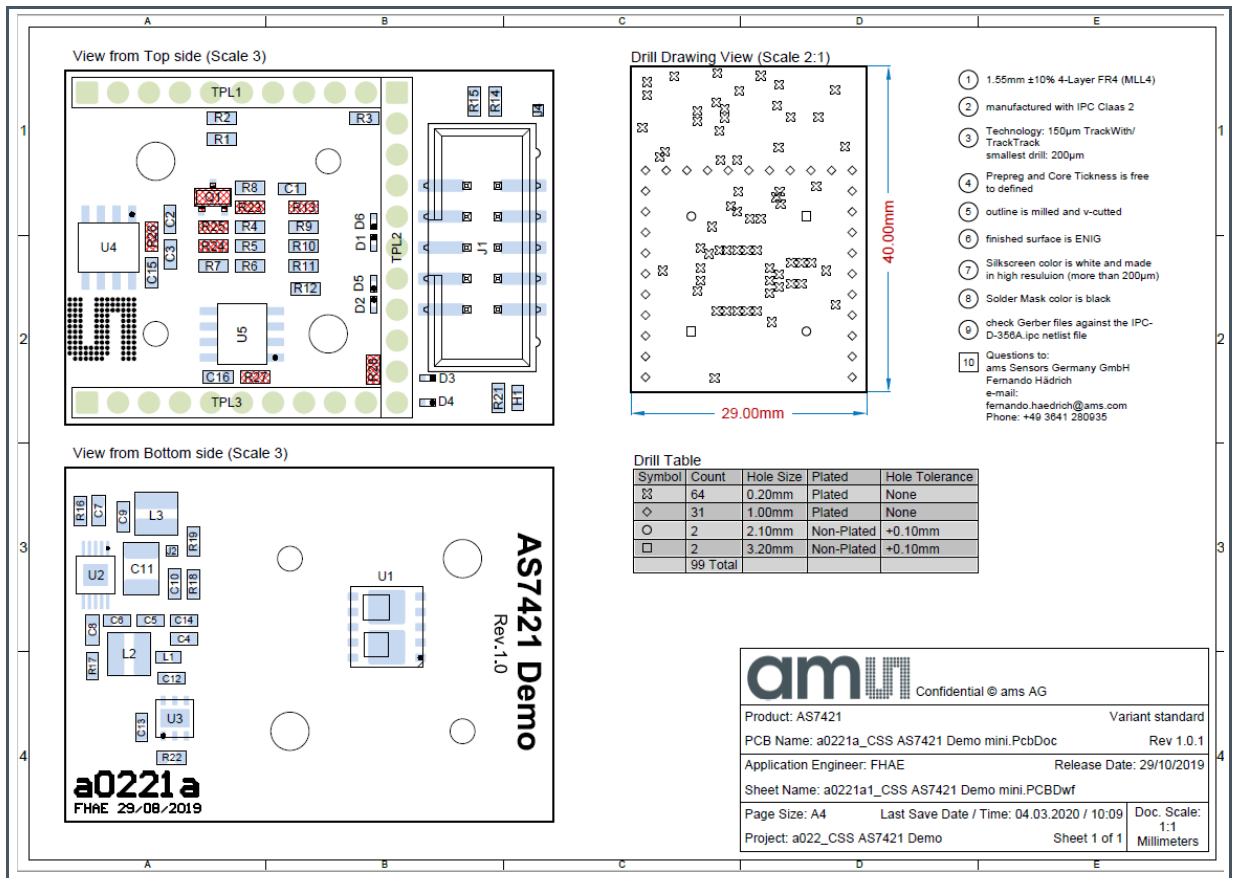

Figure 11:
AS7421 Sensor Board assembly diagrams (top and bottom views)



4 Software Description

The AS7421 Windows client software is used to control and evaluate the AS7421 spectral sensor possibilities. It allows users to configure the chip, visualize the results, and store the measured data in files.

After connecting the hardware to the PC and starting it, the main menu window will open.

4.1 Graphical User Interface (GUI)

The main menu of the AS7421 GUI contains the control buttons, input fields, selection boxes, a graph plotting area, and the unique ID of the connected device

4.1.1 Overview

The AS7421 Demo GUI consists of three main segments:

- **Settings Area** – This area (1 in Figure 12) contains the configuration and connection information data.
- **Header Line Area** – Additional functions can be called in this area (2 in Figure 12).
- **Plotting/Diagram Area** – This area (3 in Figure 12) shows a graph plot, which is used to visualize measured data in various ways.

Figure 12:
AS7421 GUI main menu

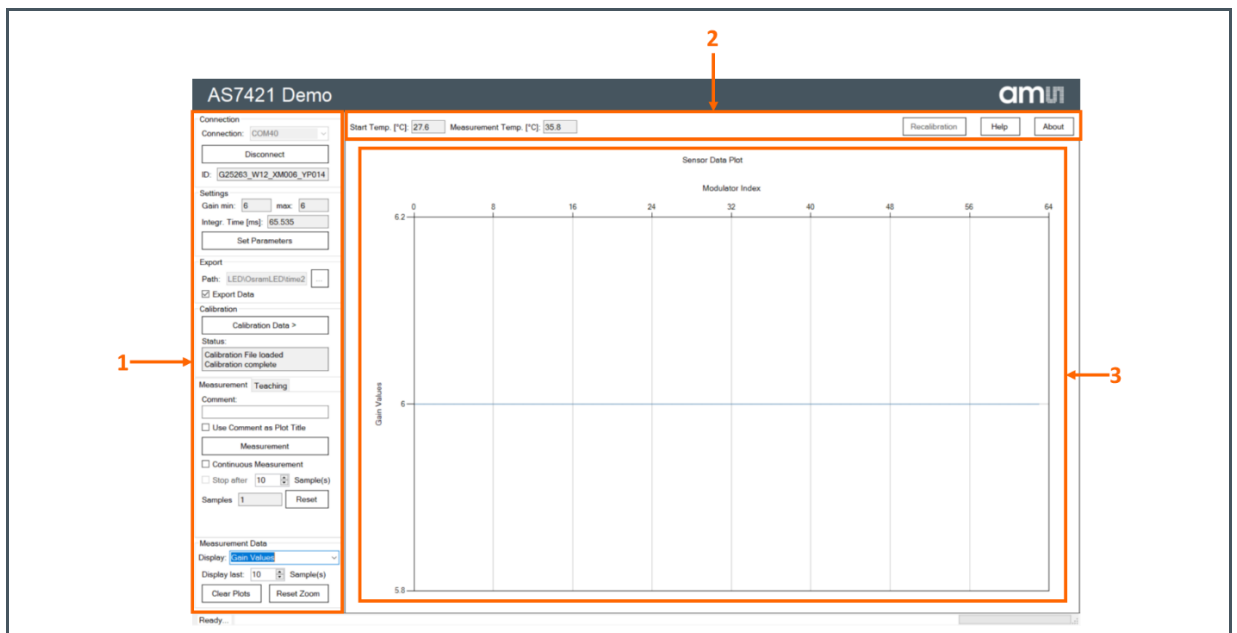

4.1.2 Connecting to a device

After starting the GUI software, select the correct COM port from the drop-down menu and press “Connect”. If no EVK COM port appears, check the connection and make sure both green LEDs on the Unicom board and the green LED on the sensor board are switched on.

Figure 13:
Connection



As soon as the connection to the Unicom board is successful, the sensor’s unique ID displays in the ID field.

When connecting to the Unicom board for the first time, the software will ask for an appropriate calibration file. The calibration file can be found on the USB stick under “\Custom_Device_Calib_File” (see chapter 5.1.5). Select the calibration file that contains the unique ID of the sensor board in its name.



Information

If no matching calibration file is present, please contact ams-OSRAM and provide the corresponding unique ID number.

4.1.3 Starting a Measurement

For a measurement with standard configuration data, click the Measurements button.

The standard configuration consists of two parts:

- The settings for the client software, which are loaded at start-up. These settings are always saved when the client software is closed.
- The AS7421 sensor’s calibration data, sourced from the appropriate calibration file.



Information

Without calibration data, measurements are not possible.

Measurement data and calibration results can be exported to CSV files using the export checkbox. If the data export is not active, a dialog will be displayed after pressing the “Measurement” button.

Either activate the export and remember the setting or just ignore it. When export is activated, a folder for data storage must be selected.

Figure 14:
Dialog box of an inactive export

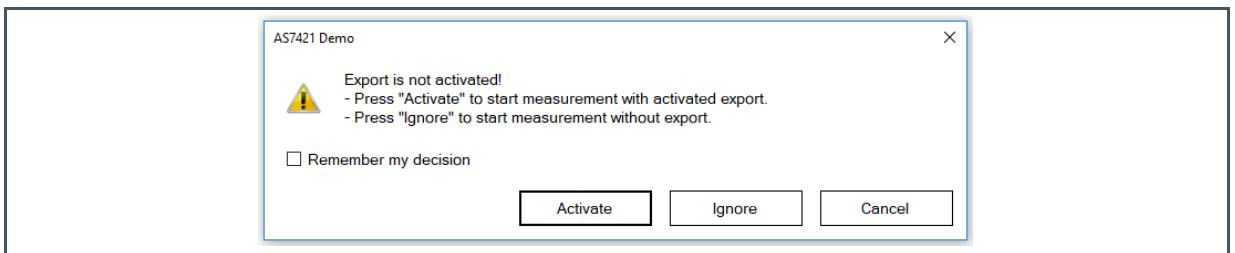

After the selection, measurement starts and the results are shown in the plotting area.

Figure 15:
Main GUI window with the measurement data

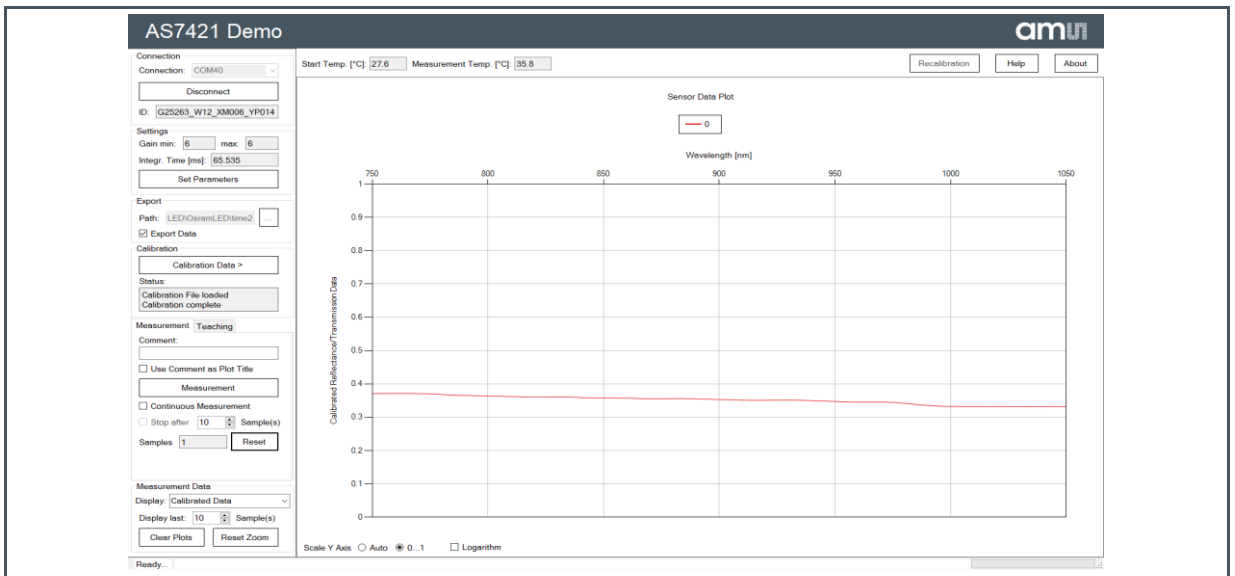

5 Description of the GUI Main Menu Areas

5.1 Settings Area

In the settings area, a user can configure several parameters of a measurement, as well as the input and output data. The area is split into six groups or tabs, as shown in Figure 16.

- Connection tab (1 in Figure 16)
- Settings tab (2 in Figure 16)
- Export tab (3 in Figure 16)
- Calibration tab (4 in Figure 16)
- Measurement/Teaching tabs (5 in Figure 16)
- Measurement Data tab (6 in Figure 16)

Figure 16:
GUI Overview of the Settings Area

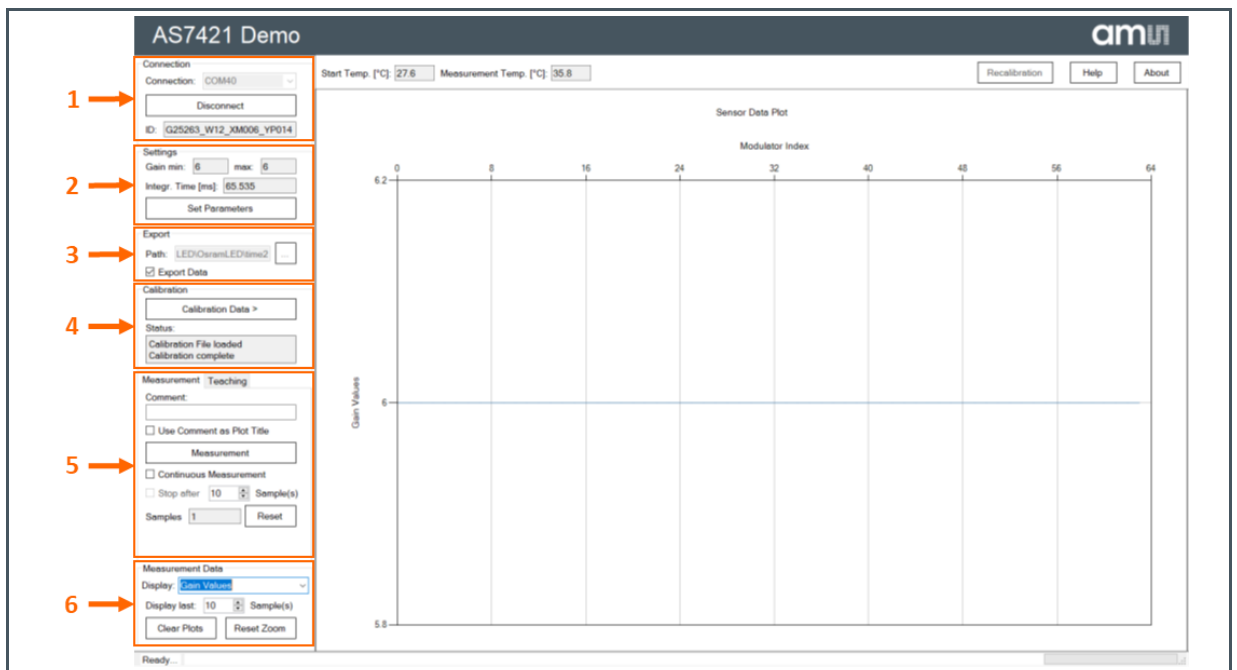

5.1.1 Connection tab

Please refer to chapter 4.1.2 for more information on this dialog.

5.1.2 Settings tab

This tab displays parameters with the current settings of the connected AS7421 64-channel NIR spectral sensor.

The values displayed in this field are the minimum Gain (Gain min) and the maximum Gain (max). This indicates the lowest and highest Gain values selected among all 64 channels of the sensor for measurement. All the gain factors of the channels are equal or between these values. For displaying the actual gain factor of each of the 64 channels, please refer to chapter 5.1.7 by choosing "Gain Values".

In the field "Integration Time", the activated Integration time is displayed in milliseconds.



Information

After the successful connection of the sensor and selecting the relevant calibration ("Sensor" or "Custom Device") file for the chip ID, which is important, the default parameter settings such as gain, integration time, LED setting, etc. are automatically loaded from the device configuration section of the selected calibration file.

Figure 17:
Settings tab

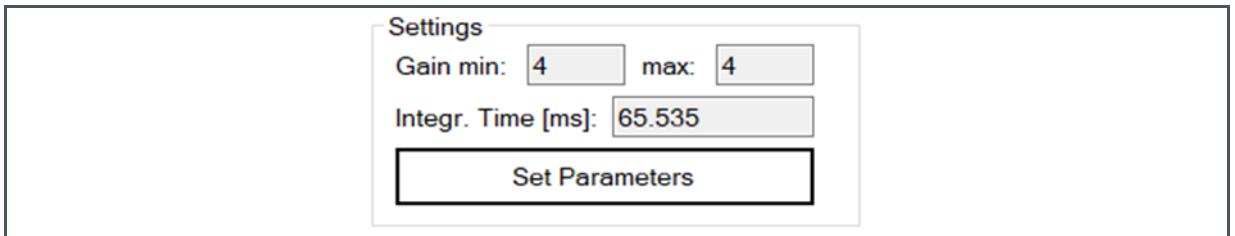

5.1.3 Set Parameters

In the settings tabs, user-specified parameters can be set under the "Set Parameters" button. By clicking this button, a new dialog window appears with the following four tabs:

- Hardware
- Calibration File
- Measurement
- Teaching

Hardware

Figure 18:
Set Parameters – Hardware page

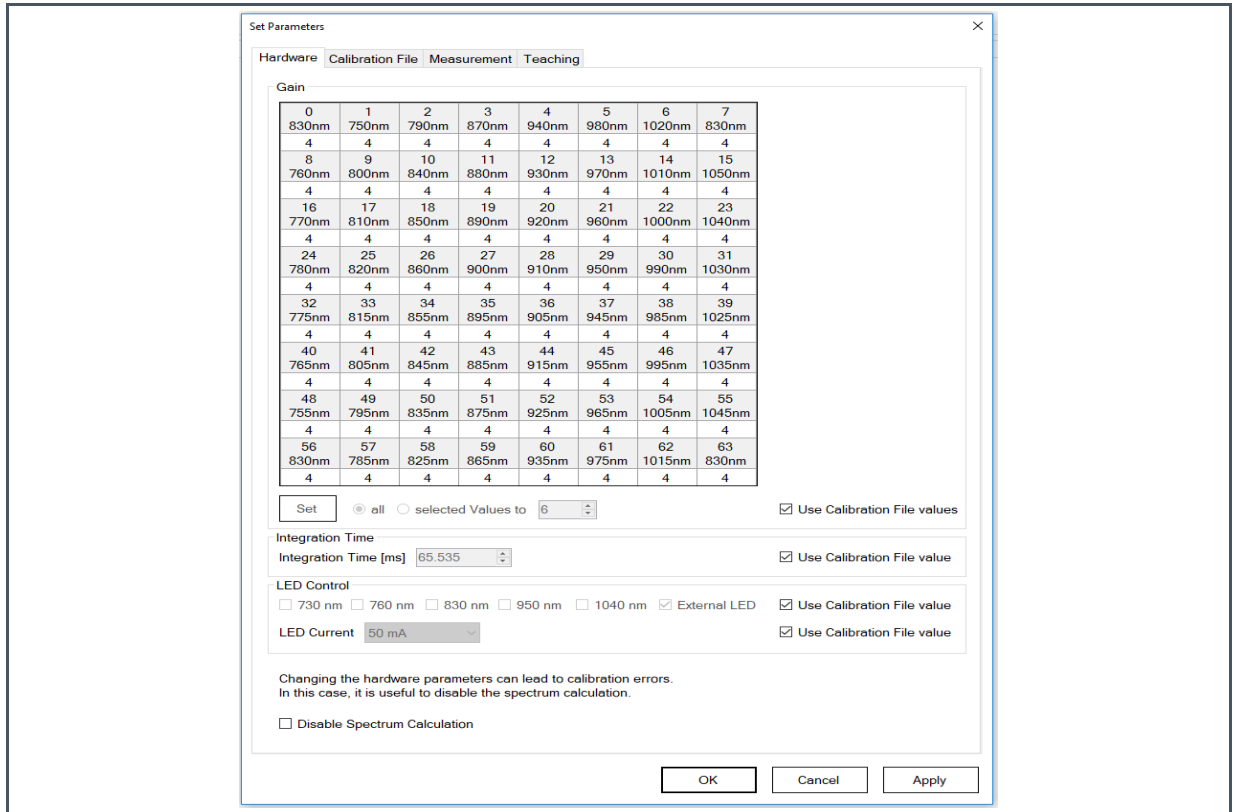

- **“Use Calibration File values” checkbox:** By activating this checkbox for gain, integration time, and LED parameter fields, the corresponding values saved in the device configuration of the calibration file are taken into consideration. To change any of these parameter settings, the user has to uncheck the “Use Calibration file values” checkbox and input the necessary values.



Information

It is very important to recalibrate (follow the Calibration procedures) when the parameters in Set Parameters are changed. Otherwise, a user can only measure raw data without the calibration procedure. If not to attain a calibrated spectrum, the user has to re-select the old calibration file via the calibration window (see “Open calibration File” under the chapter: Calibration Data tab for details).

The Set Parameters - Hardware window is split into four sections as shown in Figure 18:

- **Gain** – The matrix shows the 8x8 sensor channel array with corresponding wavelength response and default gain setting per sensor channel. By default, the values are sourced from the device configuration in the selected calibration file.

The user can modify the gain of each channel by unchecking "Use Calibration File", in three methods:

- **One value:** Activate the radio button "selected Values", then, click the left mouse button in the field you need to change and type the new value.
- **More values:** Activate the radio button "selected Values", press "Shift" and click again and again with the left mouse button in the fields you need to change. Lastly, type the new value.
- **All values:** Activate the radio button "All Values" and set the value in the input field.

After performing one of these methods and pressing the "Set" button, modify the gain values in the sensor according to the intended method.

- **Integration Time**

- **"Integration Time [ms]" input field:** Apart from the default integration time from the calibration file, a user-defined value of Integration time can be set in milliseconds. The integration value assigned is equally applicable for all 64 channels.

- **LED Control** – The AS7421 Evaluation kit contains five internal NIR LEDs (see the Datasheet for more details). Aside from that, evaluation kit demo boards can implement an external LED. An external LED is implemented on the GPIO pin of the demo board after necessary rework or adaptation. However, please keep in mind that an external LED requires a separate calibration. Please refer to the document [2] for more details on using an external LED with the AS7421 EVK. The calibration file for internal LEDs won't work with the external LEDs. The AS7421 Demo GUI gives a user the option to perform calibration for both internal and external LEDs. (Please refer to the document [3] for more details on calibration with the internal LEDs of the AS7421 EVK.)

The LEDs can be enabled and disabled with the provided checkboxes. It is also possible to adjust the LED current. By default, 760nm, 830nm, 950nm, and 1040nm LEDs are configured in the "Sensor Calibration File" calibration file. Changing the LEDs configuration causes the LED current to require a recalibration.

To use an external LED, make the necessary hardware changes and only check the external LED checkbox in the GUI. A user has to generate a new calibration file by following the steps to generate a calibration file with an external LED (see chapter 6).

- **"Disable Spectrum Calculation" checkbox** – This checkbox disables the spectrum calculation using the calibration file, causing the GUI to plot only RAW measurement values. If some parameter settings are changed to user-defined values and these values are different from calibration files, this option can be used.

Calibration

Figure 19:
Set Parameters – Calibration page

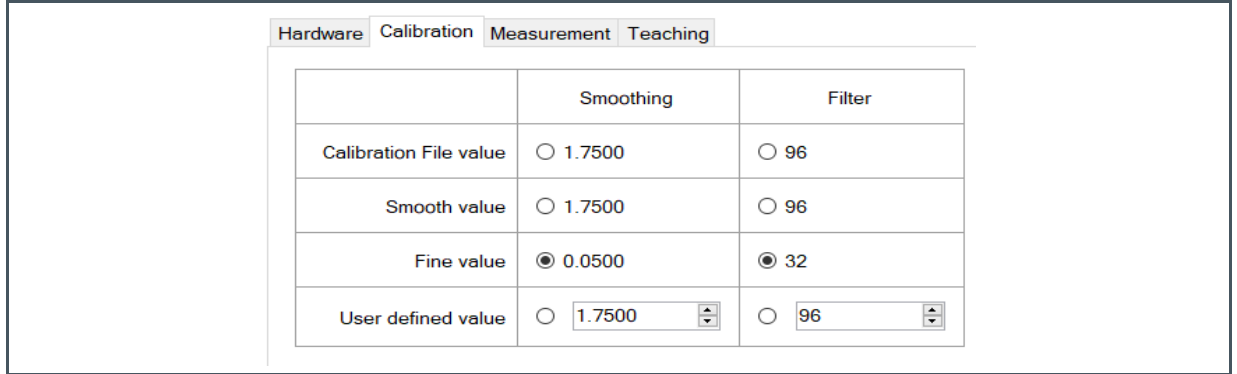

The measurement spectra are post-processed by two filters. Smoothing and filter are two characteristic filters (Figure 19). In this window, filter characteristics can be adjusted to predefined values or user-specific values. Smaller values for smoothing and filters will show detailed spectral information but this will also amplify noise in the spectra.

Measurement

Figure 20:
Set Parameters - Measurement page

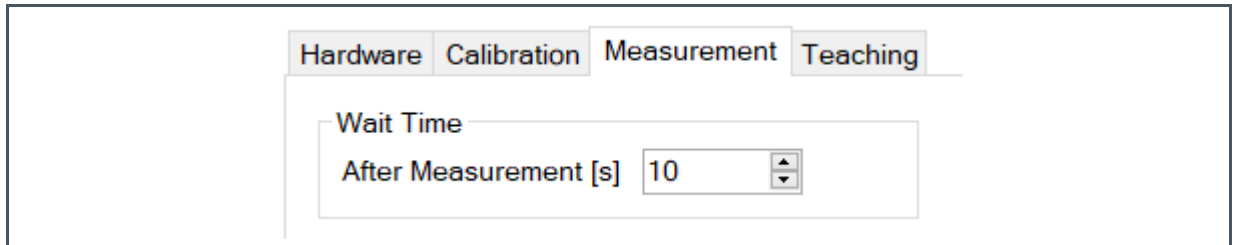

This window contains the group "Wait Time - After Measurement". This field inputs the wait time after a measurement cycle is finished. "Continues Measurement", defines the wait time between two consecutive measurement cycles. The default value is ten seconds.

Teaching

Figure 21:
Set Parameters – Teaching

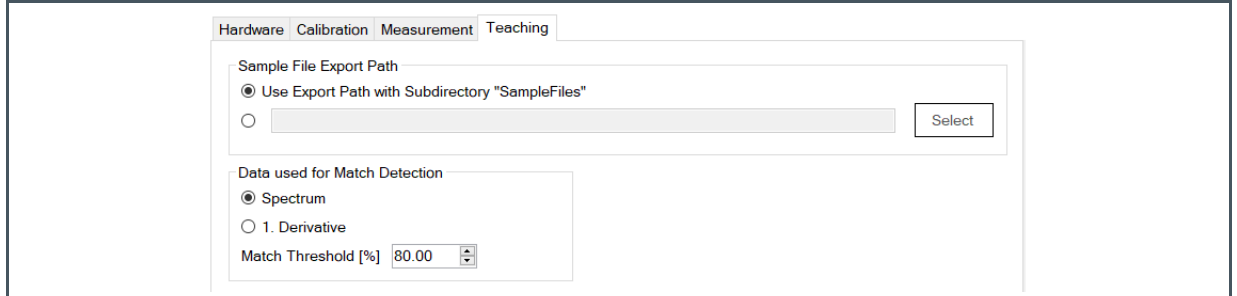

This tab page has two main areas:

- **Sample file export path:** Here, the directory is defined as where the teaching Data are stored. It must be different from the standard export path. Two ways are available from the defined directory, which are activated by a radio button (Figure 21):
 - **“Use the Export Path with Subdirectory ‘SampleFiles’” input file** – Use this option if the path is a subdirectory of the export path.
 - **“Use full directory Export Path” input field** – This is used to define the full path of the directory for the teaching data.
- **Data used for Match Detection:** By selecting a radio button, you can select the data type of the match detection.
 - Spectrum
 - 1. Derivative
 - "Match Threshold [%]" input field – A number to set the trigger threshold in percent. This means a factor of the matching similarity by comparing the actual measured data with the saved teaching data. If the value of comparison by the saved data is above the number in the "Match Threshold" field, the result is a member of the grading list. This list is shown in the combo box "matching sample (similarity)", described in the chapter: Teaching. The default value of the "Match Threshold" is 80%.

5.1.4 Export tab

Figure 22:
Export tab

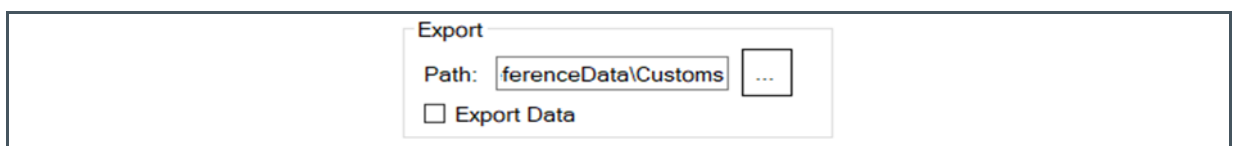

In the "Path" field, the full pathname of the directory, where the software writes down various data files, is filled (Figure 22). The user can write the pathname or use the button "..." for selecting the path via a dialog window.

By activating the "Export Data" checkbox, data files will be written into the directory named above in the Export path. These settings are valid for all exported data and protocol files. By default, this checkbox is set to active.

5.1.5 Calibration tab

This tab is used to organize a user-specified calibration of the AS7421 NIR sensor. A sensor-specified calibration file is first needed for measurement. There are two types of calibration files: "Sensor" and "Custom Device".

Figure 23:
Calibration tab

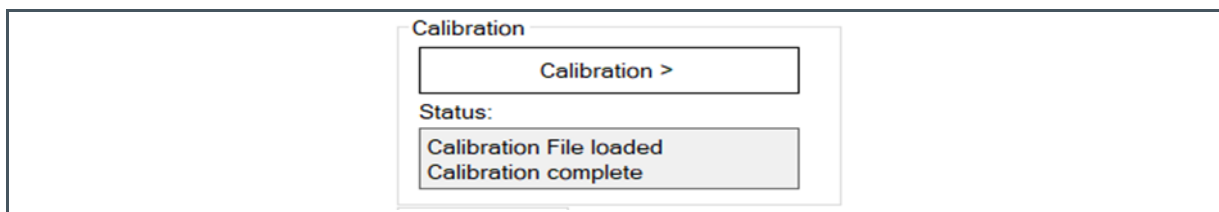

The "Sensor" calibration files are created during the production of the final test in the factory. The "Sensor" calibration files contain the Chip ID, Sensor data (individual filter response), LED data, Temperature channel data, and Device configuration (parameter setting at the final test such as Gain, Integration Time, etc.) and does not include data related to calibration. Therefore, a calibrated spectrum calculation is not possible with the "Sensor" calibration files. Instead, this file is selected for raw measurement without any calibration.

The "Custom Device" calibration file contains various compensation data for the optical path of the final system, as well as reference data for the calibration. The "Custom Device" calibration file helps to derive the calibrated data from a raw value and generates the necessary calibrated spectral data, along with the first and second derivatives.

The EEPROM of the AS7421 Demo board is loaded with a "Custom Device" calibration file generated in-house. Apart from that, the USB stick in the Demo kit is loaded with "Sensor" and "Custom Device" calibration files. A user can perform their custom calibration based on the setup and save the data to the EEPROM or select it directly from the directory.

Calibration Status

The Calibration tab includes the "Calibration" button, followed by two status lines. The status lines have three states:

- No calibration file has been loaded:
 - status-line 1: calibration file not loaded
 - status-line 2: <empty>
 - Please load a calibration file.
- A calibration file is loaded, but some more calibration tasks are needed:
 - status-line 1: calibration file loaded
 - status-line 2: calibration not complete

This state is shown when a calibration file of "Sensor Calibration File" is loaded. In this case, additional calibration data are needed. Please refer to the section below and carry out the calibration methods "Temperature calibration", "White reference" and "Black reference". Alternatively, a fully functional "Custom Device" calibration file with finished calibration steps can be loaded to get the status "calibration complete".

- All calibration data are complete:
 - status-line 1: calibration file loaded
 - status-line 2: calibration complete

This final state status is needed for measurement of calibrated spectrum data and for displaying calibrated spectrum data in the plot.



Information

After loading a "Custom Device" calibration file, this state is shown.

Calibration Data tab

Figure 24:
Calibration Data tab

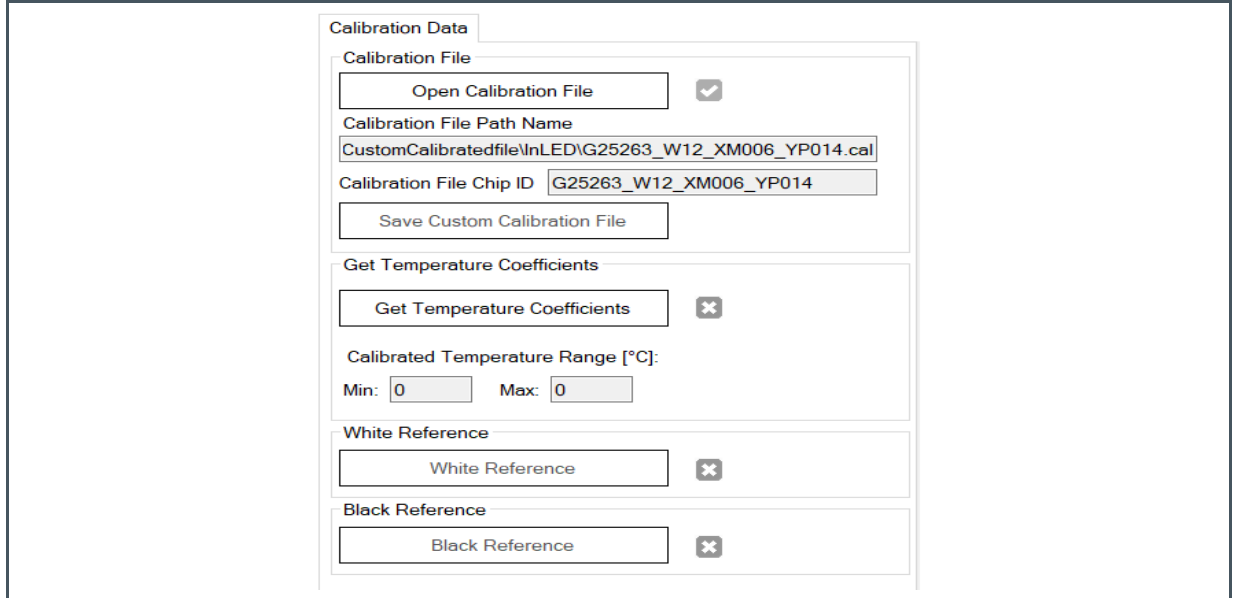

Clicking on the “Calibration” button opens a new column with the following calibration options:

- **Open Calibration File** – Usually, a calibration file can be loaded from the USB drive, but the GUI software also allows the generation of a new user-specified calibration file for a new sensor environment or any sensor parameter changes. If the parameters (Gain, Integration time, and LEDs Settings) of the sensor settings are modified, it is highly recommended to do the new calibration with the required parameter setting of the user’s choice. If any of the parameters are changed in the GUI, the GUI considers measurement without the calibrated spectrum calculation file after generating a warning message as shown in Figure 25.

Figure 25:
Measurement warning for incomplete calibration (occurs if the Sensor calibration file is loaded)

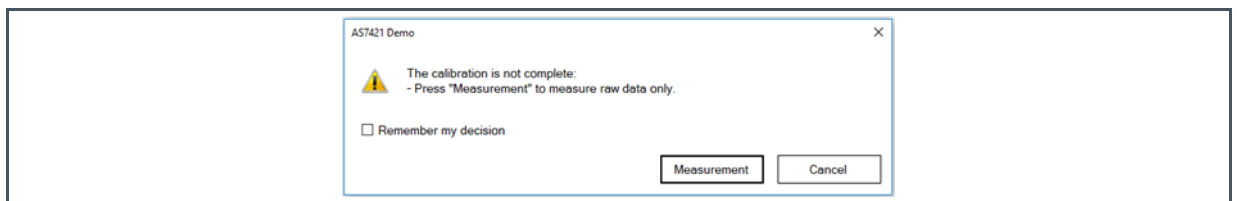

By clicking the "Open Calibration File" button, an external calibration file can be loaded from a new dialog window.



Information

Take note of the Filter option in this window:

- **Calibration Data Files *.cal:** Only shows Calibration Files.
- **Calibration Data Files by Chip ID:** This shows Calibration Files whose Filename includes the ID of the connected AS7421 Sensor Chip.

Figure 26:
Open Calibration File dialog

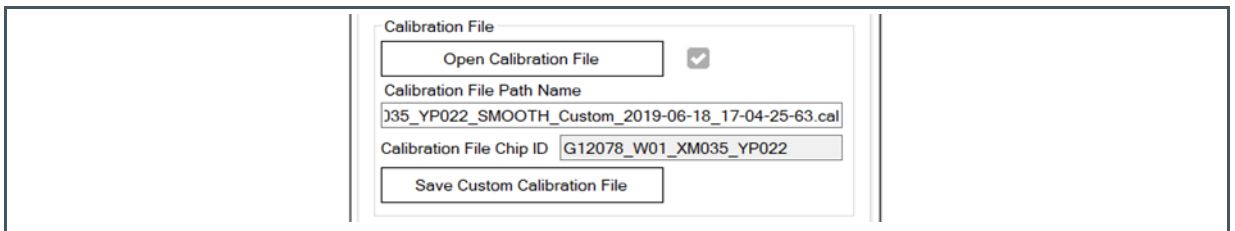

It is very important to select the corresponding calibration file, including the unique ID of the sensor board in the calibration file. The sensors' unique ID is shown in the ID field of the connection section in GUI. If no matching calibration file is available, please contact ams-OSRAM and provide the sensor board ID number.

Figure 27:
Error message after wrong calibration file is selected

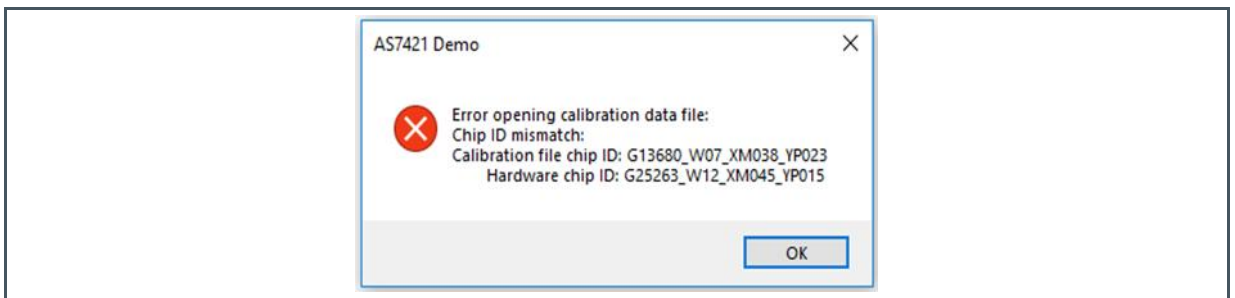

- **Save Custom Calibration File** – The "Save Custom Calibration File" button opens a window for saving a user-specified calibration file to a disc (*.cal). The default filename structure is: <Loaded filename with ID> + custom_timestamp.cal



Information

To activate the “Save Custom Calibration File” button, the status of the calibration must be “complete”.

The original calibration file should never be overwritten. The software generates new data files in a binary format into the calibration data directory.

- Get Temperature Coefficients (only for internal LEDs)** – In this option, new temperature coefficient data for the “Custom Device” calibration file are measured. For measuring the temperature coefficients, place the sensor on the reference target and press “Get Temperature Coefficients”. A status message “Temperature calibration is running” will display while the measurement is progressing. The message “Ready” appears after completing the measurements.



Information

For external LEDs, the temperature calibration is not executed in the Demo GUI since this effect mainly comes from the internal NIR LEDs.

Figure 28:
Get Temperature Coefficients

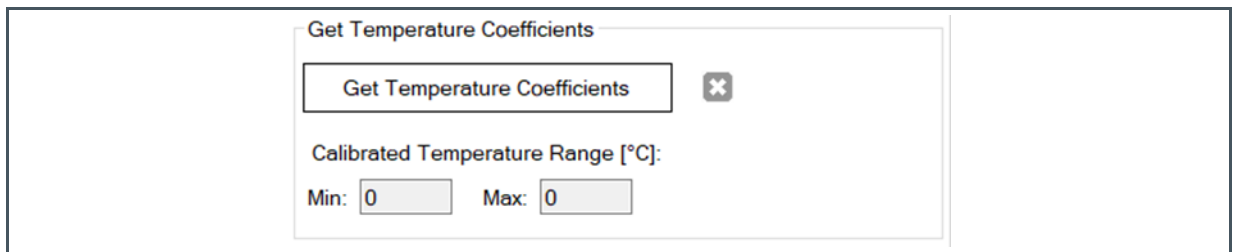

- White Reference** – In this option, new calibration data for a white reference target can be generated. The user also has to provide the reference spectrum file of the white reference target.

Figure 29:
White reference option



- Black Reference** – This option is nearly the same as the “White Reference”. Once again, a reference spectrum file for a black target should be provided.

Figure 30:
Black reference option

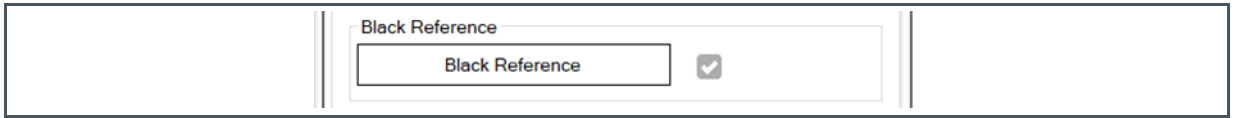

5.1.6 Measurement/Teaching tabs

This tab is divided into two pages.

- Measurement tab page
- Teaching tab page

Measurement tab page

Figure 31:
Measurement tab page

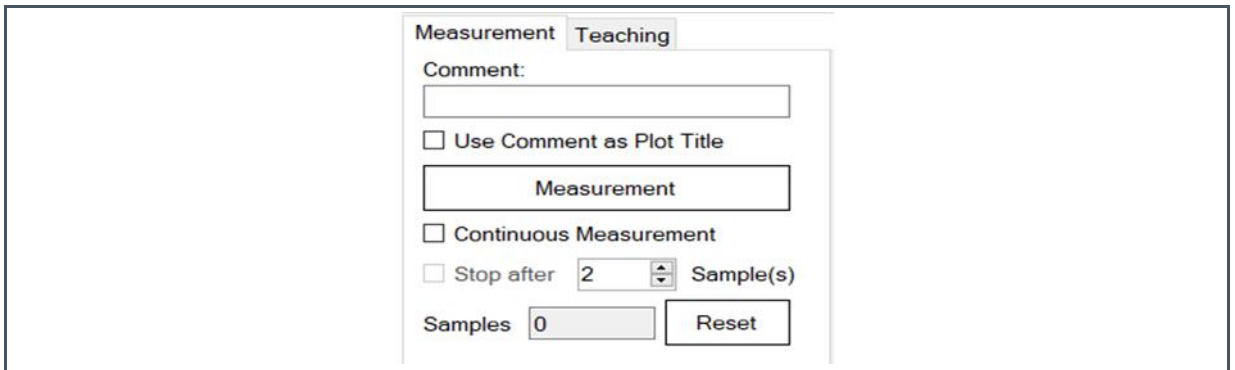

In this area, the measurement and the output of data can be controlled.

- **"Comment"**: In this input text field, a user-defined description can be written. The description is part of the output data logged into a CSV file and is connected to the next measurement results. The field is optional and text is not required.
- Checking the "Use Comment as Plot Title" checkbox would display the comment mentioned as the title for each measurement cycle.
- **"Measurement" button**: This button starts a single measurement cycle. A single measurement cycle consists of one "Dark measurement" and ten "single LED pattern" measurements. "Continuous Measurement" measures the value in a continuous loop until "Stop Measurement" is pressed. Checking the "Stop after" checkbox and mentioning the n samples would execute the measurement loop for n times. The "Samples" textbox updates the count of each measurement cycle executed. The "Reset" button clears the previous measurements and set the measurement cycle count to zero.

Teaching tab page

Figure 32:
Teaching tab page

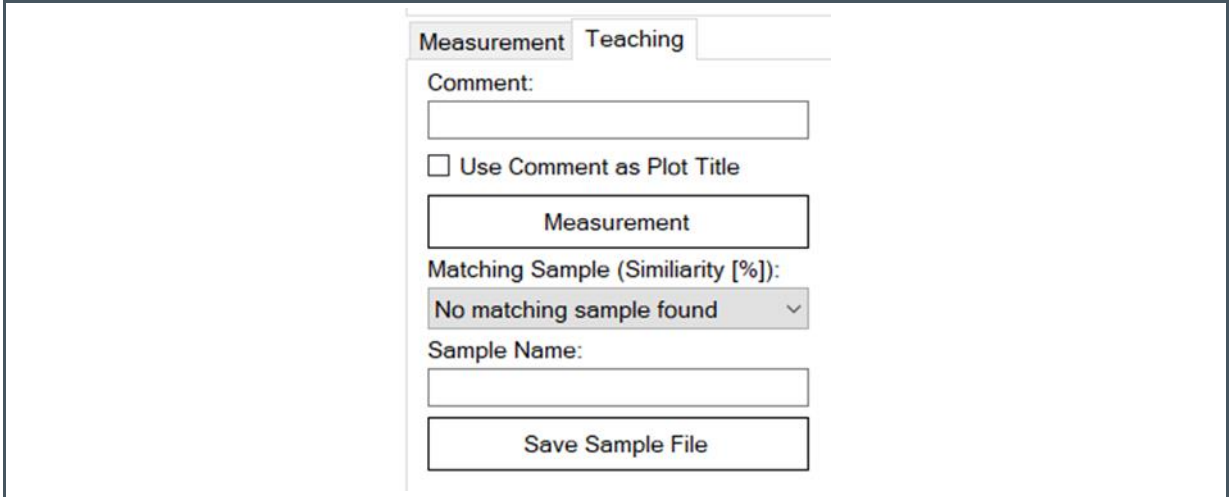

The screenshot shows a software interface with two tabs: "Measurement" and "Teaching". The "Teaching" tab is active. The interface contains the following elements:

- A "Comment:" label followed by a text input field.
- A checkbox labeled "Use Comment as Plot Title".
- A button labeled "Measurement".
- A label "Matching Sample (Similarity [%]):" followed by a dropdown menu showing "No matching sample found".
- A "Sample Name:" label followed by a text input field.
- A button labeled "Save Sample File".

- **"Comment" input field:** Use this comment as the plot title, like the same named field in the Measurement tab page.
- **"Measurement" button:** This button starts a single measurement. This measurement result will be used for comparison with the existing database samples or as a reference measurement for a new sample spectrum.
- **"Matching Sample (Similarity [%])" combo box:** The name of the best matching result from the Teaching database to the actual measurement is shown in this field. The name is followed by the similarity in percent. The dropdown menu shows the next closest matches.
- **"Sample Name" input field and "Save Sample File" button:** Here, the user can define an applicable name for the actual measurement. Subsequently, the data values can be saved into the Teaching database by clicking the "Save Sample File" button. After saving, the results are available for matching with the next measurements.
The Teaching database is located in a separate directory. All dataset files in this directory are included for matching the measurement results. The files are named with the text from the field "Sample Name" field.

5.1.7 Measurement Data tab

Figure 33:
Measurement Data Area

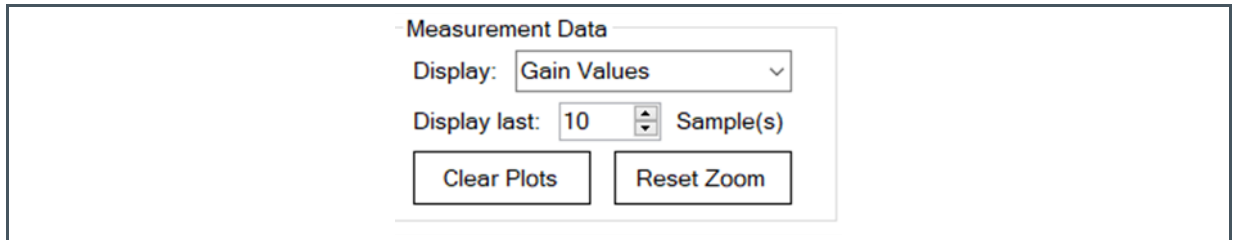

In this area, the user can select different available data type from the list to display in the plot area.

The following fields and options can be used:

- **"Display"**: Select one option from the dropdown menu. The options with their description are shown in Figure 34.

Figure 34:
Display options

Menu option	Description	Diagram x-axis	Diagram y-axis
RAW data	Original sensor measurement data as counts.	Channel Number (0-63)	Values in 16-bit
Calibrated data	The Calibrated Reflectance/Transmittance data generated from the RAW data after Calibration (based on the used application).	Wavelength (750nm–1050nm)	0...1
First Derivative	First derivative of the Calibrated data.	Wavelength (750nm–1050nm)	First derivative with Factor 10^5
Second Derivative	Second derivative of Calibrated data.	Wavelength (750nm–1050nm)	Second derivative with Factor 10^6
Teaching data	The calibrated data saved using the teaching function.	Wavelength (750nm–1050nm)	0...1
White Reference	White reference raw data present in the calibration file or the last measured white reference	Channel Number (0-63)	Values in 16-bit
Black Reference	Black reference raw data present in the calibration file or the last measured black reference.	Channel Number (0-63)	Values in 16-bit
Gain Values	Gain value of each of the 64 channels from the AS7421 sensor	Channel Number (0-63)	Factors of Gain

5.2 Header Line Area

The header line area is located at the top of the plotting graph area (Figure 12). It contains the following buttons:

- About
- Help
- Recalibrate
- Measurement Temperature
- Start Temperature

5.2.1 About

This opens a new window showing the release numbers of all the included modules.

5.2.2 Help

This button opens the user manual in pdf format.

5.2.3 Recalibration

The recalibration function calculates and exports measured raw data into the calibrated spectrum based on a selected calibration file. The calibration file can be different from the one belonging to the connected sensor.

To enable the recalibration function, it is necessary to disconnect from the sensor (“Disconnect” button). Otherwise, the “Recalibration” button will be disabled.

Figure 35:
Recalibration window

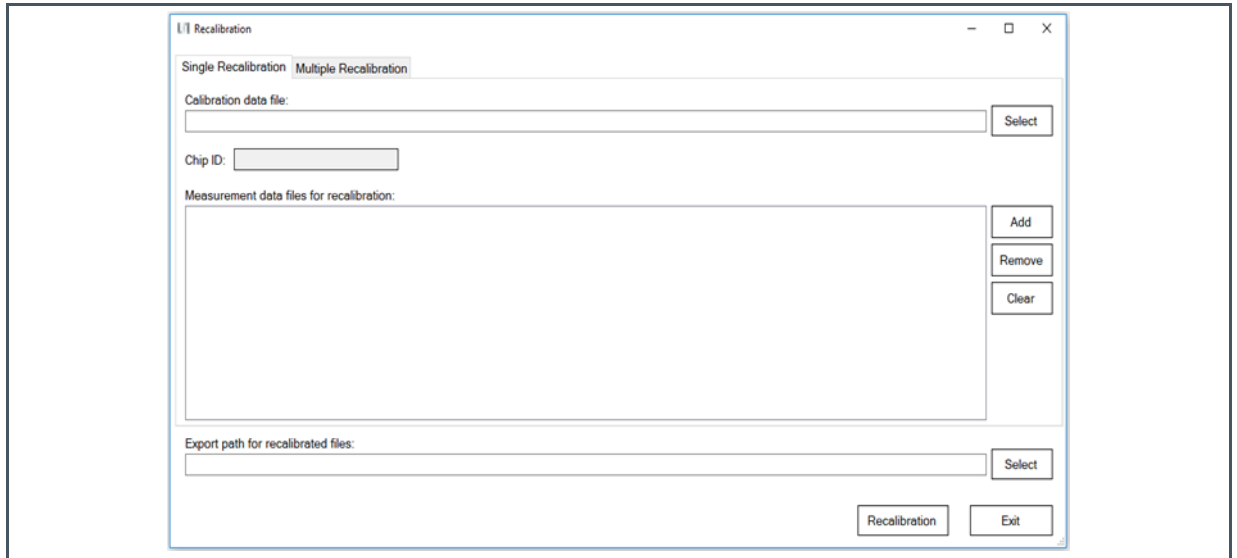

There are two different methods of performing recalibration:

- Single Recalibration:** In Single Recalibration, a recalibration is performed by selecting a “Custom Device” calibration file of the user’s choice, followed by selecting measurement data files (Exported CSV log file) using the “Add” button. Selecting the calibration file will input the device configuration and other relevant data for the calibrated spectrum calculation, and the measurement log file will give the raw data as input. Then, the user must select the export path for saving the recalibrated file. Pressing the “Recalibration” button will generate a calculated spectrum from the measurement data files (raw values) and calibration file. This data will be saved as a CSV file in the selected export path.
- Multiple Recalibration:** This generates the calculated spectrum from a selected calibration file and the selected measurement data log files. Unlike Single Recalibration, the folder containing the “Custom Device” calibration file is selected and the first calibration file in that directory is considered. Selecting the Measurement data file path causes a loop through all the measurement data files in that directory, generating the calculated spectrum for all the measurement data files in the selected directory. Similar to Single Recalibration, all the generated individual files for each of the measurement data files are saved into the selected export path.

5.2.4 Start & Measurement Temperatures

Figure 36:
Temperature of the sensor for measurement

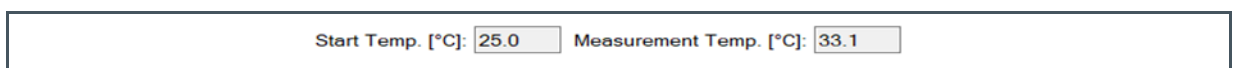

The start temperature measures the actual temperature of the sensor (in degree Celsius). The measurement temperature field shows the power-on temperature of the sensor (in degree Celsius).

5.3 Plotting/Diagram Area

Once the relevant "Custom Device" Calibration file is selected for the sensor and the measurement is completed with the calibration, the measurement data are shown in a graphical diagram (Figure 37).

Figure 37:
Main menu with plotting area highlighted

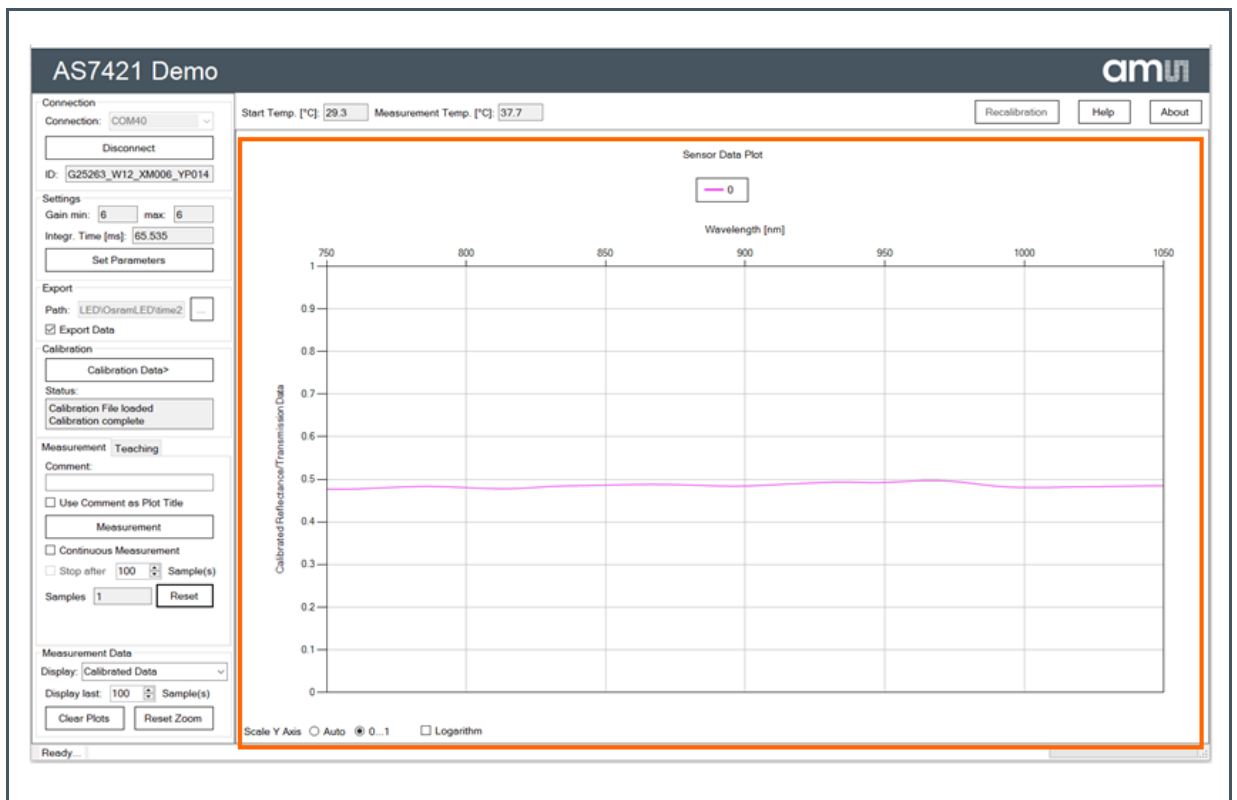

If more than one curve is displayed, each one has its unique color. Above the diagram is a legend indicating the correspondence between the color and the number of the measurement cycle. The newest curve is named "0", with previous curves moving to the right-hand side with receding numbers.

The diagram's axes have a different meaning depending on the kind of measurement. Please refer to Figure 34 for values and units.

Usually, the diagram's y-axis scale is set to "Auto". If a measurement is set to "Calibrated Data", some buttons are activated under the diagram. These are grouped into an area named "Scale Y-axis" and includes the following buttons:

- "Auto": For an optimized scaling.

- "0-1": To show the full value range on the y-axis.
- "Logarithm": To display results on a logarithmic scale.

The Diagram area also includes a graphical zoom function with three steps for activating it:

1. Place the cursor in the upper left corner of the partial window.
2. Then, press and hold the left mouse button.
3. Move the cursor to the lower right corner of your partial window and release the mouse button.

To recall the default zoom, click the "Reset Zoom" button in the measurement data area.

6 Custom Calibration

The following steps are taken when performing a custom calibration.

1. After the successful connection of the sensor to perform a new calibration, select the calibration tab.
2. Pressing the “Open Calibration File” opens a dialog window for selecting a calibration file.

Figure 38:
Calibration file selection window

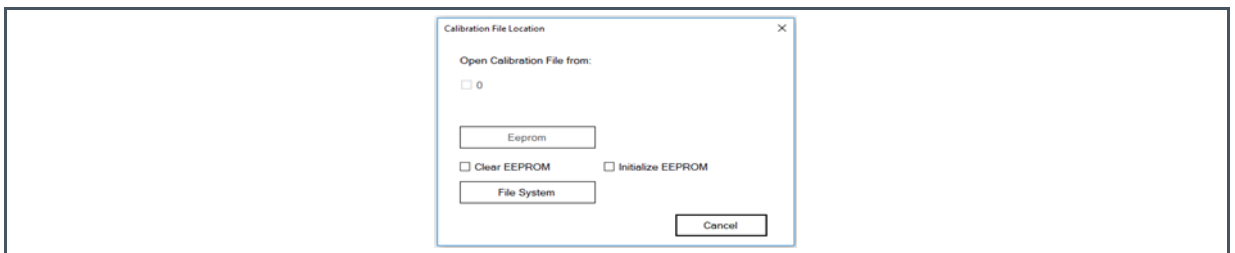

3. Open the “Sensor” calibration file provided by ams-OSRAM from the desired location by selecting the “File System” button. Once the “Sensor” calibration file is correctly selected (Chip ID should match), a tick is marked adjacent to the button.

Figure 39:
Calibration Data tab

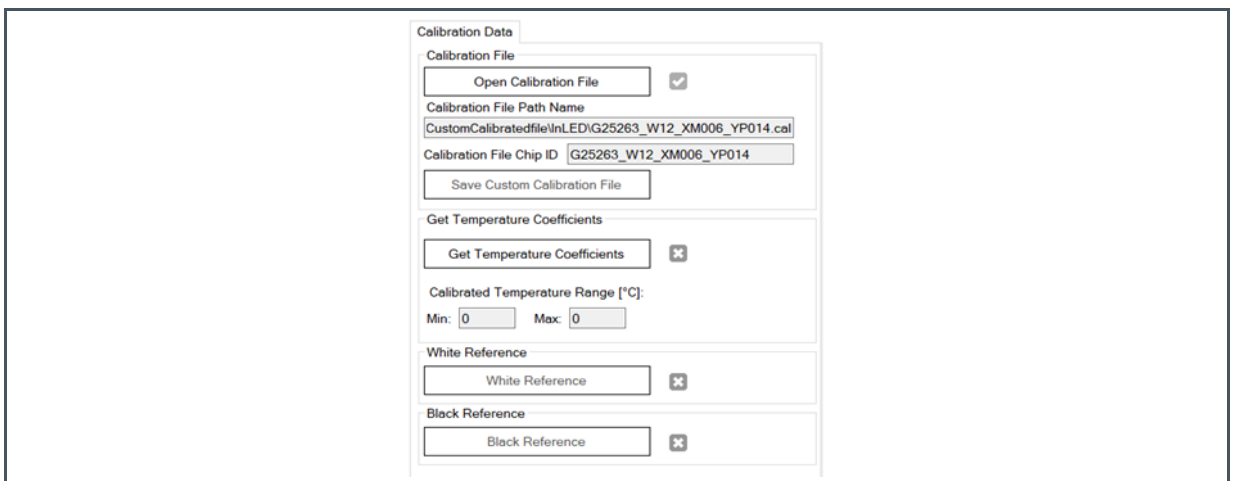

4. To perform calibration for a different parameter setting or external LED, which is optional based on the application, navigate to “Set Parameters”, uncheck “Use Calibration File values”, and implement the necessary changes in the settings.
5. For external LED calibration, uncheck the five internal LEDs and retain the external LED checked in the LED control of the Set Parameters window. Pressing “OK” will confirm these parameters as a new device configuration in the calibration file.
6. Afterward, navigate back to the Calibration Tab and perform the “Get Temperature Coefficients” if the external LEDs are not selected. If the external LED is selected, the “Get Temperature Coefficients” step is ignored.
7. For performing “Get Temperature Coefficients”, place the reference target (grey or white) on the sensor and press the “Get Temperature Coefficients” button. Please activate the measurement exports if necessary. If the Checkbox "export" in the main window is active, the calibration measurements protocol will be exported to the selected file location with the file name: AS7421_Demo_ Temperature_Calibration _<ChipID>_<Timestamp>.csv.
8. The user can observe the progress of the measurement in the bottom toolbar. Once the measurement is finished, a “Ready” status is displayed in the bottom toolbar, the cross mark turns to a tick mark, adjacent to the “Get Temperature Coefficients” button, and the calibrated temperature range is shown in the textbox respectively.
9. Afterward, the reference target on the sensor is replaced with a white reference target, and the corresponding reference spectrum is selected by pressing the “White Reference” button. This initiates the measurement, and when the measurement finishes, the status is notified with “Ready” in the bottom toolbar. Once again, finishing a measurement would display a tick mark adjacent to the “White Reference” button.
10. The same procedure described above from steps 1 to 9 for the white reference is repeated for a black target. Please do not forget to replace the white target with a black target.
11. After the successful completion of all the mentioned steps, the “Save Custom Calibration File” button is activated to save the new custom calibration file to the desired location with a file name: <Sensor_ChipID>_Custom_<Date>_<Time>

Figure 40:
Calibration Data file after calibration ends

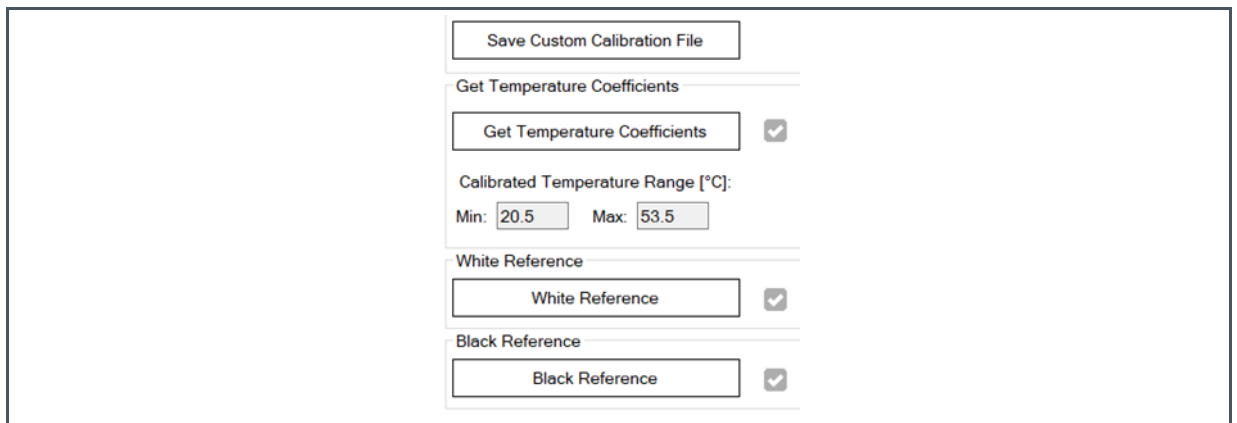

6.1 EEPROM

The AS7421 Demo board is integrated with an EEPROM for storing the Calibration file. The EEPROM of the AS7421 Demo board in the evaluation kit is loaded with a “Custom Device” calibration file generated in-house. The user can replace the calibration file on the EEPROM with the custom calibration file generated by following the steps outlined in chapter 6. The “Open Calibration File” button generates the window to save the calibration file to the EEPROM. “0” in Figure 41 shows that no file is copied into the EEPROM.

Figure 41:
EEPROM window for the calibration file

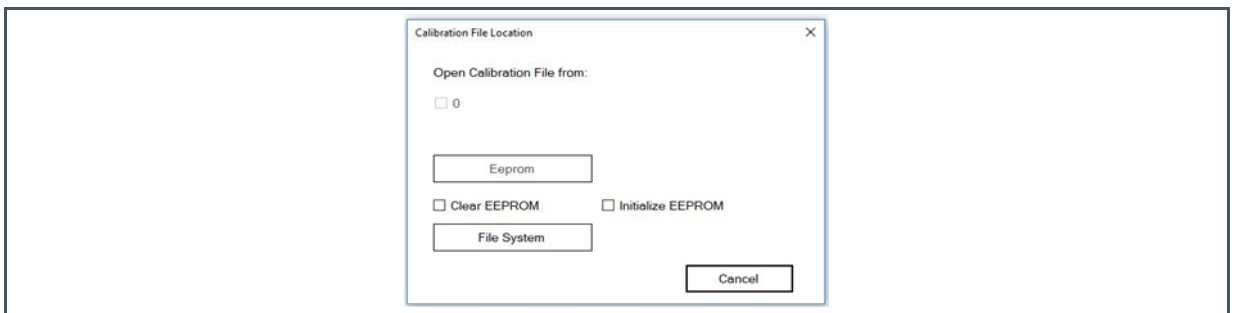

To load the calibration file to the EEPROM, check the “Initialize EEPROM” checkbox and select the calibration file to be copied into the EEPROM using the “File System” button.

When the calibration file data is copied to the EEPROM, the bottom toolbar displays the status message “Write calibration data to EEPROM”. Once the data is successfully fully copied, “Ready” is displayed in the toolbar. Reopening the window with the “Open Calibration File” button shows the loaded calibration file.

Figure 42:
EEPROM window after calibration file of custom device is loaded

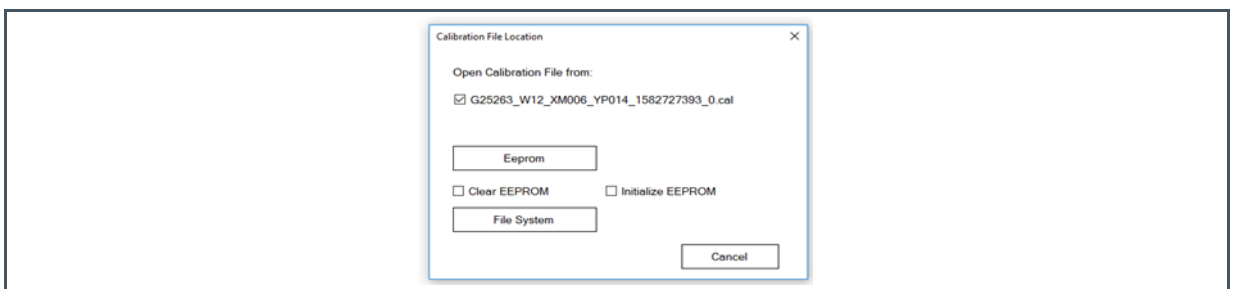

To use the calibration file from the EEPROM, a user has to check the check box in front of the loaded file and select the EEPROM button.

To rewrite the EEPROM with a new calibration file, a user has to clear the already loaded file from the EEPROM. To do that check the “Clear EEPROM” checkbox, this will turn the “File System” button into “Clear EEPROM Only”. Pressing the “Clear EEPROM Only” button will erase the already existing calibration data in the EEPROM.

Figure 43:
Function to clear the EEPROM

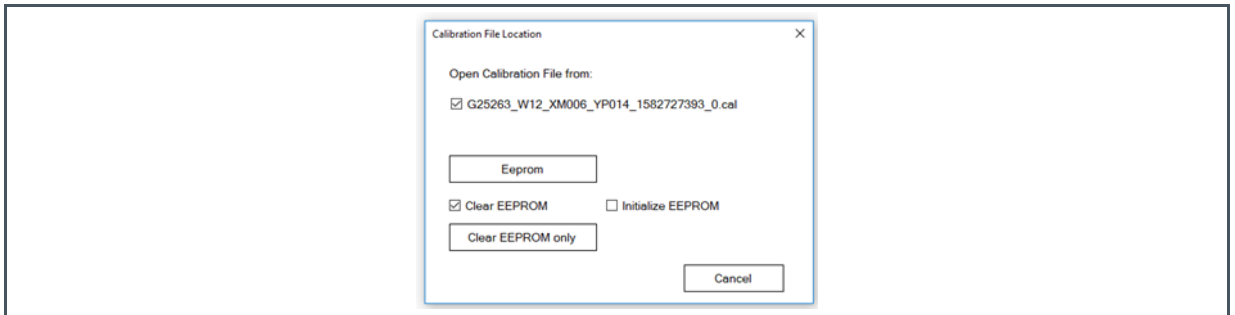

7 Additional Documents

The following list includes a selection of available documents with more technical details for the AS7421 sensor and its Evaluation Kit. This list is not fixed and it is constantly changing. Ask us for new details.



For further information, please refer to the following documents:

1. ams-OSRAM AG, *AS7421 64-Channel Hyperspectral NIR Sensor* (DS000667), datasheet.
 2. ams-OSRAM AG, *AS7421 External LED Synchronization* (AN001026), application note.
 3. ams-OSRAM AG, *AS7421 Calibration* (AN001053), application note.
-

8 Revision Information

Changes from previous version to current revision v0-01	Page
Initial version	

- Page and figure numbers for the previous version may differ from page and figure numbers in the current revision.
- Correction of typographical errors is not explicitly mentioned.

9 Legal Information

Copyrights & Disclaimer

Copyright ams-OSRAM AG, Tobelbader Strasse 30, 8141 Premstaetten, Austria-Europe. Trademarks Registered. All rights reserved. The material herein may not be reproduced, adapted, merged, translated, stored, or used without the prior written consent of the copyright owner.

Demo Kits, Evaluation Kits and Reference Designs are provided to recipient on an "as is" basis for demonstration and evaluation purposes only and are not considered to be finished end-products intended and fit for general consumer use, commercial applications and applications with special requirements such as but not limited to medical equipment or automotive applications. Demo Kits, Evaluation Kits and Reference Designs have not been tested for compliance with electromagnetic compatibility (EMC) standards and directives, unless otherwise specified. Demo Kits, Evaluation Kits and Reference Designs shall be used by qualified personnel only.

ams-OSRAM AG reserves the right to change functionality and price of Demo Kits, Evaluation Kits and Reference Designs at any time and without notice.

Any express or implied warranties, including, but not limited to the implied warranties of merchantability and fitness for a particular purpose are disclaimed. Any claims and demands and any direct, indirect, incidental, special, exemplary or consequential damages arising from the inadequacy of the provided Demo Kits, Evaluation Kits and Reference Designs or incurred losses of any kind (e.g. loss of use, data or profits or business interruption however caused) as a consequence of their use are excluded.

ams-OSRAM AG shall not be liable to recipient or any third party for any damages, including but not limited to personal injury, property damage, loss of profits, loss of use, interruption of business or indirect, special, incidental or consequential damages, of any kind, in connection with or arising out of the furnishing, performance or use of the technical data herein. No obligation or liability to recipient or any third party shall arise or flow out of ams-OSRAM AG rendering of technical or other services.

RoHS Compliant & ams Green Statement

RoHS Compliant: The term RoHS compliant means that ams-OSRAM AG products fully comply with current RoHS directives. Our semiconductor products do not contain any chemicals for all 6 substance categories plus additional 4 substance categories (per amendment EU 2015/863), including the requirement that lead not exceed 0.1% by weight in homogeneous materials. Where designed to be soldered at high temperatures, RoHS compliant products are suitable for use in specified lead-free processes.

ams Green (RoHS compliant and no Sb/Br/Cl): ams Green defines that in addition to RoHS compliance, our products are free of Bromine (Br) and Antimony (Sb) based flame retardants (Br or Sb do not exceed 0.1% by weight in homogeneous material) and do not contain Chlorine (Cl not exceed 0.1% by weight in homogeneous material).

Important Information: The information provided in this statement represents ams-OSRAM AG knowledge and belief as of the date that it is provided. ams-OSRAM AG bases its knowledge and belief on information provided by third parties, and makes no representation or warranty as to the accuracy of such information. Efforts are underway to better integrate information from third parties. ams-OSRAM AG has taken and continues to take reasonable steps to provide representative and accurate information but may not have conducted destructive testing or chemical analysis on incoming materials and chemicals. ams-OSRAM AG and ams-OSRAM AG suppliers consider certain information to be proprietary, and thus CAS numbers and other limited information may not be available for release.

Headquarters

ams-OSRAM AG
Tobelbader Strasse 30
8141 Premstaetten
Austria, Europe
Tel: +43 (0) 3136 500 0

Please visit our website at www.ams.com

Buy our products or get free samples online at www.ams.com/Products

Technical Support is available at www.ams.com/Technical-Support

Provide feedback about this document at www.ams.com/Document-Feedback

For sales offices, distributors and representatives go to www.ams.com/Contact

For further information and requests, e-mail us at ams_sales@ams.com